

Premium Adjustable Metal Expansion Wristband

- **Premium metal expansion wristband.**
Comfortable, designed not to pinch or pull hair.
- **Durable metal band.**
Long wearing, easy to clean.
- **Superior contact with skin.**
For reliable removal of generated static charges.
- **Patented adjustment band changes quickly and easily to any size.**
One size fits all, only one item number to purchase and stock. No «extra» links to lose.
- **Non-flaking or scratching laminated insulator on all external surfaces.**
Protects wearers from electrical hazards. Provides many years of product life.
- **Medical grade stainless steel interior expansion band.**
Will not cause allergic skin reactions for most people.
- **Date coded.**
Providing lot traceability to ensure quality control.
- **Designed to satisfy Wrist Strap requirements of IEC 61340-5**
- **Per EN 61340-5-1 paragraph 5.5 EPA working practices**
“The primary means of grounding personnel shall normally be by a wrist strap connected to an EBP.” Paragraph 5.2.7 “The wrist strap shall consist of a band that fits snugly around the wrist and a cord to connect the band to an EBP. The wrist strap shall incorporate a quick release connection. The cord shall have a termination compatible with the EBP and shall incorporate at least one insulated current-limiting resistor. The total resistance from hand to EBP shall be in accordance with table 1 [Rg 7,5 x 10⁵ to 3,5 x 10⁷ ohms].”

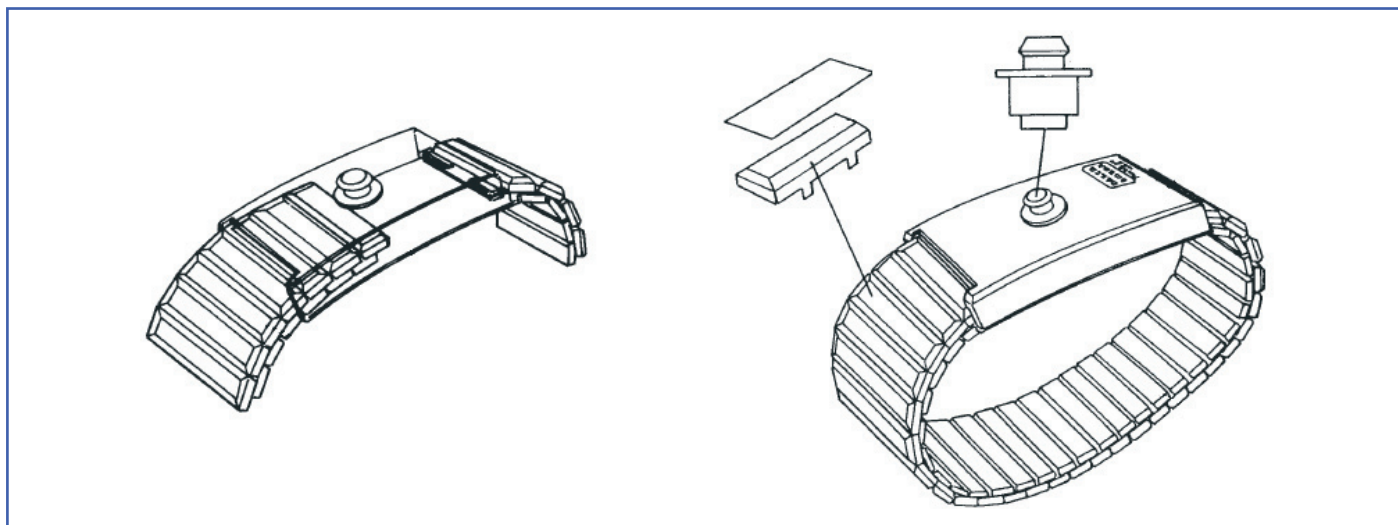

| Art. | Description |
|-----------|----------------------------|
| ESD 60150 | 4mm stud, X-large version |
| ESD 60108 | 10mm stud, X-large version |
| ESD 60148 | 4mm stud version |
| ESD 60106 | 10mm stud version |