

SPECIFICATIONS CABLE CLAMP TRI 53-66

- Application** : Suitable for fitting 3 single- and multiple-conductor low- medium and high voltage cables.
- Range** : For cables with a nominal outer diameter from 53 up to 66 mm.
- Material** : Black polyamide, fibreglass-reinforced, virgin material. It is halogen-free and resistant to radioactive rays, UV rays, salt water, ozone, oils, acids, fuels and alkalis.
- Flame resistance** : UL94 V-0 and classification following DIN 5510-2:2009 with flammability class S3, smoke SR2 and dripping ST-2.
- Standards** : According to International Standard NEN-EN-IEC 61914:2016, Certificate of Conformity KOZ No 20117C by SGS.
- Flexure strength** : 210 N/mm²
- Tensile strength** : 120 N/mm²
- Thermal expansion** : 0,01% per 10°C temperature increase.
- Temperature limits** : Permanent application from -80°C to +120°C. Brief heating up to +220°C.
- Benefits** : The central fastening hole in the bottom part of the TRI clamps means they can be fastened to e.g. masts and poles, as well as to concrete and fitting rails.



Initial torque for fastening fixing material : 5 – 8 Nm (depends on cable manufacturer's prescription).

Tests have been done by KEMA Netherlands, SGS Belgium, Underwriters Laboratories Inc. and Schneider France.

All products listed in this catalogue are fully compliant manufactured with the latest EU Directive 2011/65/EU (RoHS) list Meeting all legal obligations under REACH.

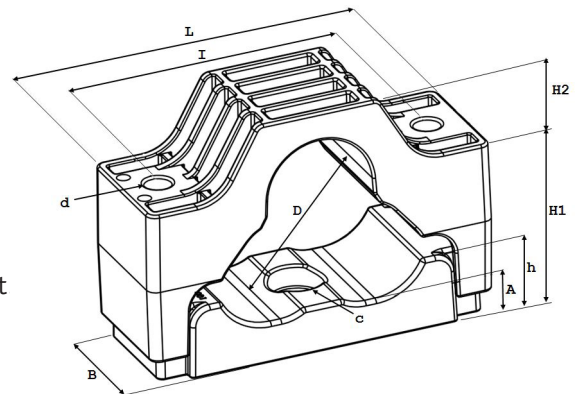

Dimensions in millimeters

Type	DØ	L	B	I	dØ	H1	H2	h	A	C	Strength (N)
KZ TRI 53-66	53-66	216	80	169	15	100-120	44	44	25	15,5	69.000